



## Automatic float control valve



Art. CV100X

Flanges drilling: UNI EN 1092-2 PN 10, PN 16, PN 25

Installation: horizontal as per scheme

FIELDS OF APPLICATION: tanks ° towers ° aqueducts °  
pools

Epoxy painting suitable for potable drinking water  
applications

The automatic float control valve, installed at the inlet of tank/reservoir, allows to keep a constant level of water. The body of the main valve is a globe valve, and thanks to the float linked to the pilot valve, this float control valve ensures to stop water filling at a predetermined level, while realizes water supplement when the float lowers. The valve can work in remote, perfect for all those applications where the water tank is not easily accessible. This float control valve has a high accuracy of level control, avoids the water hammer effect and it is easy to install and to maintain.

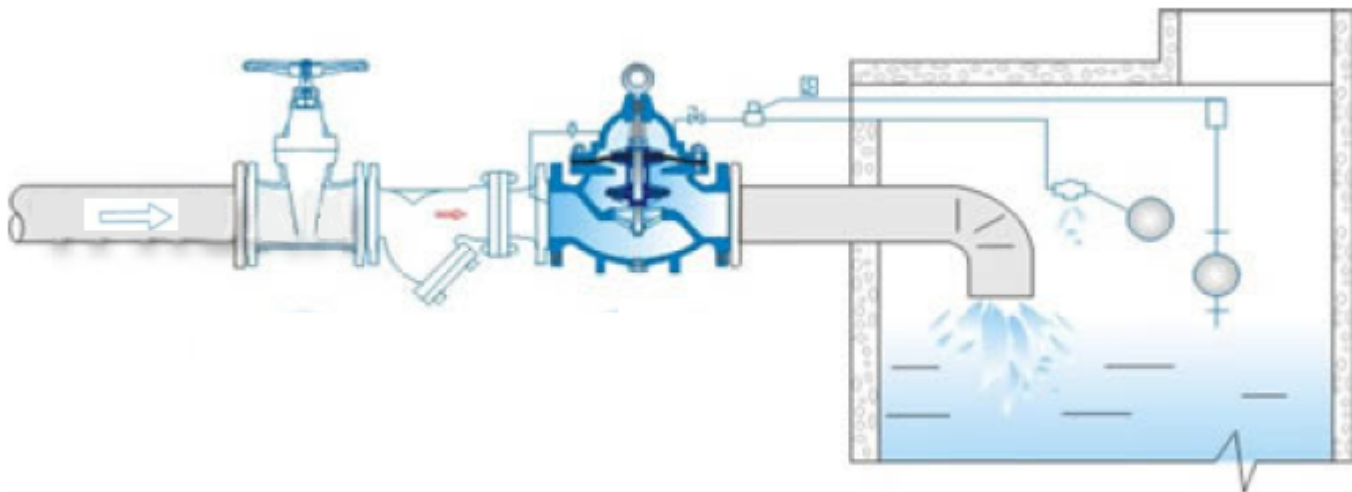

## Materials

body/bonnet/disc	ductile iron GGG50, EN-GJS-500
stem	stainless steel AISI410
diaphragm	NBR
seat	2Cr13
spring	50CrVA
ball valve	brass
bolting	stainless steel
painting	epoxy

## Dimensions

DN	L mm	PN 16		H mm
		D mm	D1 mm	
50	203	160	125	265
65	216	180	145	310
80	241	195	160	350
100	292	215	180	460
125	330	245	210	520
150	356	280	240	570
200	495	335	295	695
250	622	405	355	780
300	698	460	410	905
350	787	520	470	1025
400	914	580	525	1080
450	978	640	585	1030
500	978	705	650	1135
600	1230	840	770	1270

