



Single ball air release valves PN 16



Art. 704

Installation: at the high part of the pipeline
APPLICATIONS • Aqueducts • Irrigation plants
Epoxy painting suitable for drinking water applications.

The single ball air release valves are used for applications related to troubles with air in the pipelines. They are useful to discharge small amount of air during the usual working conditions. Minimum pressure of air release: 0,1 bar. Available DN 40/50/65 flanged with cock, or male threaded 1" with cock, or female threaded 1" without cock.

Materials

body	cast iron GG25, EN-GJL-250
cover	cast iron GG25, EN-GJL-250
floating ball	ABS / stainless steel 304
gasket	EPDM
painting	epoxy

Dimensions

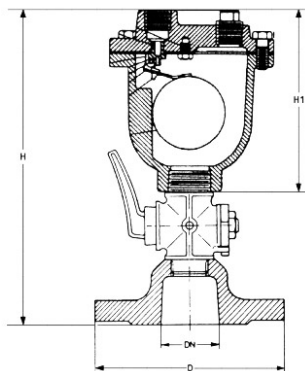

DN	H1 mm.	H mm.	D mm.	Weight kg.
40	155	260	150	6
50	155	260	165	6
65	155	260	185	7

Pressure

DN	Nominal pressure	Test pressure Mpa		Max working pressure Mpa
mm	BAR	body	seat	40°C
40-65	16	2,4	1,76	1,6

